

DT9838

Strain- and Bridge-Based Measurement Module

DT9838

Strain Measurement Module

The DT9838 module is a USB strain gage measurement device intended for full-, half-, and quarter-bridge strain gage elements and bridge-based sensor assemblies such as load cells, torque sensors, and pressure sensors. General-purpose voltage measurements are also supported. It is compatible with USB 2.0 and USB 1.1 ports.

Key Features:

- Four Simultaneous, 24-bit analog input channels and one tachometer in the analog input stream
- Direct full-bridge and half-bridge support with half-bridge completion
- Quarter-bridge support with external bridge-completion resistor
- Load cell support
- Non-bridged voltage input configuration
- Programmable input and bridge configuration
- Internal bridge excitation of 0 to 10 V in 167 μV steps
- Programmable 100 k Ω $\pm 0.1\%$ shunt resistor per channel
- TEDS (IEEE 1451.4) sensor compatible
- Software calibration of the bridge offset and gain
- Sampling frequency from 195.3125 Hz to 52.734 kHz
- Input range of ± 250 mV
- Continuously paced analog input operations
- Software-programmable trigger type (software, external digital trigger, or variable digital threshold trigger) to start analog input operations
- Sync bus (RJ45) connector for synchronizing acquisition on up to four DT9838 modules
- LEDs for monitoring the arm/trigger state and USB status
- Board-level OEM version available
- VIBpoint Framework application support
- Software and drivers compatible with Windows XP/Vista/7

Analog Input Features

The DT9838 module supports four, simultaneous, analog input channels that accept bridge sensors through RJ50 connectors on the module. Acquire data from a single analog input channel or from a group of analog input channels on the module.

The tachometer input may also be read in the analog input data stream. This feature is particularly useful when you want to correlate the analog input measurements with tachometer data.

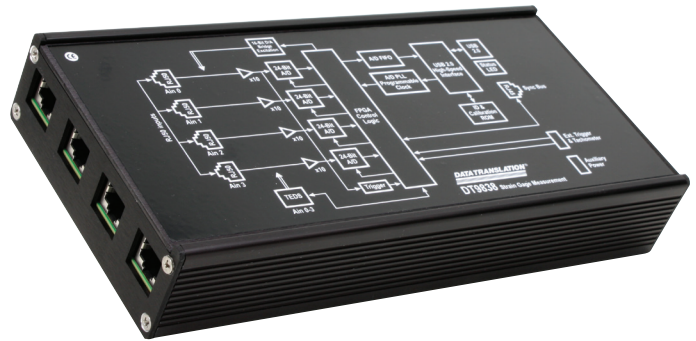

Bridge Configurations

All strain gage configurations are based on the concept of a Wheatstone bridge. A Wheatstone bridge is a network of four resistive legs, or nodes. One or more of these legs can be an active sensing element. Figure 1 shows a basic circuit diagram of a Wheatstone bridge.

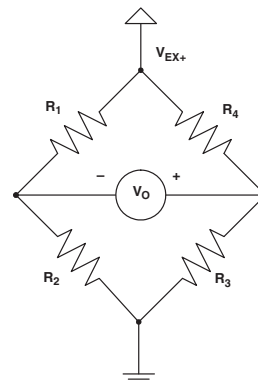

Figure 1. Wheatstone Bridge Circuit Diagram

The Wheatstone bridge is the electrical equivalent of two parallel voltage divider circuits. R1 and R2 comprise one voltage divider circuit, and R4 and R3 comprise the second voltage divider circuit. The output of a Wheatstone bridge is measured between the middle nodes of the two voltage dividers (V_0).

Physical phenomena, such as a change in strain of a specimen or a temperature shift, changes the resistance of the active sensing elements in the Wheatstone bridge. The Wheatstone bridge configuration is used to measure the small variations in resistance that the sensing elements produce corresponding to a physical change in the specimen.

A strain gage is a collection of all the active elements of a Wheatstone bridge. Different bridge configurations are used for different tasks. For each analog input channel, the DT9838 module supports the following bridge configurations to measure axial and/or bending strain:

- Quarter-Bridge
- Quarter-Bridge Temp Comp
- Half-Bridge Poisson
- Half-Bridge Bending
- Full-Bridge Bending
- Full-Bridge Bending Poisson
- Full-Bridge Axial Poisson

Note: Each channel can be configured for a voltage measurement, if a bridge sensor is not being used.

The bridge configurations, and other parameters, including the gage factor, lead wire resistance, Poisson ratio, nominal gage resistance, and excitation voltage are specified in software. The bridge configuration selected determines the way to wire the sensor elements to the channel. The circuit diagram for each of the supported bridge configurations as well as the equations that the DT9838 uses to convert voltage to strain can be found in the DT9838 User's Manual.

Transducer Support

In addition to strain gages, the DT9838 supports a variety of transducer types, including load cells, pressure transducers, and torque sensors that are based on the Wheatstone bridge.

A load cell, which consists of a number of strain gages, measures load and force by determining the deformation of a structural member as a load or force is applied. Pressure transducers, which consist of strain gages mounted on a diaphragm, measure the deformation of the diaphragm that is proportional to the pressure that is applied. Torque sensors, which consist of strain gages mounted on a torsion bar, measure the shear stress as the torsion bar turns that is proportional to the torque.

To use these transducers, configure the analog input channel for a full-bridge configuration. These transducers typically use 350 Ω nominal bridge resistance.

Instead of supplying a gage factor, use software to enter the sensitivity of the unit provided by the manufacturer of the transducer. For example, a load cell rated for 100 pounds with a 2 mV/V output has a full-scale output of 20 mV when using 10 V of excitation.

Some transducers also support TEDS or virtual TEDS. The DT9838 provides TEDS support to interface to these transducers directly.

Bridge Excitation

Through the user application software, the bridge excitation voltage can be programmed between 0VDC and 10VDC with better than 1mV of resolution. The internal bridge excitation circuitry consists of a 16-bit DAC that programs the bridge excitation for all four channels, and a separate bridge drive and sense amplifier for each channel for individual channel regulation. Each channel is also individually current limited to 50mA.

The power-efficient design of the DT9838 allows for the powering of multiple bridge configurations on multiple channels from USB power alone. For more demanding applications, bridge power capability can be further enhanced with the use of an external 5VDC to 24VDC power supply.

Remote Sensing and Lead Wire Correction

All bridge types, with the exception of the 3-wire Quarter-Bridge configuration, support the use of remote sense lines (SENSE+ and SENSE-). The remote sense lines continuously monitor the voltage that is applied across the bridge at the bridge connection points and null the effects of lead wire resistance by regulating the excitation voltage across a remotely located bridge or half bridge.

If the remote sense lines are not used to regulate the bridge, the sense lines must still be connected to the excitation lines either at the screw terminal panel or as the lines exit the RJ50 connector (connect SENSE+ to EXC+ and SENSE- to EXC-). You then have the option to correct for lead wire effects in software by entering the value of the lead wire resistance from the DT9838 module to the strain gage. Use the same gage wire for the EXC+ and EXC- lines to ensure that the resistances are matched. Using software, enter the resistance of one line, not the sum of the two lines. The software applies the correction coefficient to the bridge transfer function for the particular channel.

Note: If the remote sense leads are used, enter a lead wire resistance correction value of 0 Ω .

The module cannot detect whether the remote sense lines have been connected or not, so you must be aware of how the strain gage was wired and determine the appropriate lead wire correction value.

Shunt Calibration

Shunt calibration is another method of compensating for the lead wire resistance in the bridge. It is used to calibrate a configured channel to an artificial amount of strain that is simulated by altering the resistance of one element of the connected bridge.

With the bridge in the unstrained condition, you programmatically shunt one of the elements of the bridge with a known precision resistor value. Use either your own external resistor or the internal 100 k Ω resistor on the DT9838 module. Using software, the value of the bridge can be read, compared to the expected value, and the channel calibrated accordingly.

Offset Nulling

A balanced bridge under ideal conditions with zero strain applied produces zero volts. In practice, the output of a bridge in an unstrained condition is offset from zero slightly due to imperfect matching of bridge resistances.

It is not necessary to balance a bridge prior to the measurement. Instead, you can use software to make a reference measurement with the bridge in an unstrained condition. All subsequent data is then offset in software by the reference value.

TEDS

Each analog input channel on the DT9838 module provides a Class II TEDS (Transducer Electronic Data Sheet) interface through the RJ50 connector. The interface consists of two-wires (TEDS DATA and TEDS RETURN). TEDS is supported by some load-cells and other sensors; it is not used with strain gages.

Input Resolution

The value that is measured across the bridge of an analog input channel on the DT9838 module is amplified and applied to the 24-bit Sigma-Delta analog-to-digital converter (ADC). The ADC oversamples the incoming signal, filters the values, and produces a result.

The resolution of the analog input subsystem is fixed at 24 bits.

Input Range

The default full-scale input range for each channel is ± 250 mV.

A/D Sample Clock

The ADC master clock is generated by an internal programmable PLL and allows user programmable ADC sample rates from 195.3 S/s to 52734 S/s.

Note: According to sampling theory (Nyquist Theorem), specify a frequency that is at least twice as fast as the input's highest frequency component. For example, to accurately sample a 20 kHz signal, specify a sampling frequency of at least 40 kHz to avoid aliasing.

The modules have a passband from DC to 0.49 times the sampling rate, resulting in a maximum signal bandwidth of 25.8 kHz.

The actual frequency that the module can achieve may be slightly different than the frequency you specified due to the accuracy of the clock. You can determine the actual clock frequency using software.

Internally, the value that you specify for the internal clock frequency is multiplied by 512 to set the oscillator on the module. For example, if you specify an internal clock frequency of 50 kHz, the module sets the internal oscillator for the A/D converters to 25.6 MHz. The maximum timebase is 27 MHz.

Once the sample clock is started, the module requires 39 clock pulses before the first A/D conversion is completed (39/sample rate) due to the group delay of the converters. The software automatically adjusts for the group delay to provide only valid data in each buffer.

The tachometer data (which does not have the 39 sample group delay) is synchronized with the analog data stream. This is done through the firmware and device driver by caching the tachometer data and aligning it in time with the analog data in the user's data buffers.

Analog Input Conversion Modes

The DT9838 module supports the following conversion modes:

- Single-value mode
- Continuous scan mode

Single-Value Mode

Single value operations are the simplest to use. Using software, specify the analog input channel. The module acquires the data from the specified channel and returns the data immediately. For a single-value operation, a clock source, trigger source, scan mode, or buffer cannot be specified. Single-value operations stop automatically when finished.

Note: You cannot read the value of the tachometer using a standard single-value operation. To read these values, specify the channel as part of the analog input channel list using continuous scan mode, described next.

Continuous Scan Mode

Continuous scan mode takes full advantage of the capabilities of the DT9838 module. Use continuous scan mode to accurately control the period between successive simultaneous conversions of all channels in a channel list. A channel list, clock source, start trigger, reference trigger, post-trigger scan count, and buffer can be specified using software.

Up to five entries can be made in the channel list, including the four analog input channels (A/D channels 0 to 3) and the tachometer (A/D channel 4).

When it detects the start trigger, the module simultaneously acquires pre-trigger data from all of the input channels specified in the channel list, including the tachometer, and converts the data from the analog input channels. The sampled data is placed in the allocated buffer(s).

When the reference trigger occurs, pre-trigger data acquisition stops and post-trigger acquisition starts. The operation continues until the number of samples specified for the post-trigger scan count is acquired; at that point, the operation stops.

The conversion rate is determined by the frequency of the input sample clock. The sample rate, which is the rate at which a single entry in the channel list is sampled, is the same as the conversion rate due to the simultaneous nature of the module.

Using software, a scan can be stopped by performing either an orderly stop or an abrupt stop. In an orderly stop, the module finishes acquiring the current buffer, stops all subsequent acquisition, and transfers the acquired data to host memory; any subsequent triggers are ignored. In an abrupt stop, the module stops acquiring samples immediately; the current buffer is not completely filled, it is returned to the application only partially filled, and any subsequent triggers are ignored.

Input Triggers

A trigger is an event that occurs based on a specified set of conditions. On the DT9838 module, a start trigger source and a reference trigger source can be specified.

Pre-trigger data acquisition starts when the start trigger event occurs. When the reference trigger event occurs, pre-trigger data acquisition stops and post-trigger acquisition starts. Post-trigger acquisition stops when the number of samples you specify for the post-trigger scan count has been reached.

Start Trigger Sources

The DT9838 module supports the following sources for the start trigger:

- **Software trigger** – A software trigger event occurs when the analog input operation is started (the computer issues a write to the module to begin conversions).

- **External digital (TTL) trigger** – An external digital (TTL) trigger event occurs when the DT9838 module detects either a rising-edge (positive) or falling-edge (negative) transition on the signal connected to the Ext Trigger pins (pin 3 and 4) of the J6 screw terminal connector on the module.
- **Analog Threshold trigger** – An analog threshold trigger event occurs when the signal on a specified analog input channel rises above or falls below a programmable threshold level. The following parameters are specified using software:
 - Start trigger source – Specify a positive (low-to-high transition) threshold trigger to trigger when the signal rises above a threshold level, or a negative (high-to-low transition) threshold trigger to trigger when the signal falls below a threshold level.
 - Threshold channel – Specify any one of the analog input channels as the threshold input channel.
 - Threshold level – Specify a value between –10 V and 10 V as the threshold level.
- **Sync Bus trigger** – When multiple DT9838 modules (or multiple DT9838 and DT9837 Series modules) are connected together using the Sync Bus (RJ45) connector, the slave module can receive a trigger from one of the other modules. Specify the synchronization module as slave.

Reference Trigger Sources

The DT9838 module supports the following sources for the reference trigger:

- **External digital (TTL) trigger** – An external digital (TTL) reference trigger event occurs when the DT9838 module detects either a rising-edge (positive) or falling-edge (negative) transition on the signal connected to the Ext Trigger pins (pin 3 and 4) of the External Trigger and Tachometer (J6) connector on the module. Using software, specify the reference trigger source as an external, positive digital (TTL) trigger or an external, negative digital (TTL) trigger.
- **Threshold trigger** – A threshold reference trigger event occurs when the signal on a specified analog input channel rises above or falls below a programmable threshold level. Using software, specify the following parameters:
 - Start trigger source – Specify a positive (low-to-high transition) threshold trigger if you want to trigger when the signal rises above a threshold level, or a negative (high-to-low transition) threshold trigger if you want to trigger when the signal falls below a threshold level.
 - Threshold channel – Specify any one of the analog input channels as the threshold input channel.

- Threshold level – Specify a value between –250 mV and +250 mV as the threshold level. (In the VIBpoint Framework application, this value is specified in the appropriate engineering units for the channels, such as microstrain.)
- **Sync Bus trigger** – When multiple DT9838 modules (or multiple DT9838 and DT9837 Series modules) are connected together using the Sync Bus (RJ45) connector, you can set the reference trigger of a slave DT9838 module to Sync Bus if you want to receive a Sync Bus trigger from one of the other modules to stop pre-trigger acquisition and start post-trigger acquisition.

Tachometer Input Features

A tachometer signal with a range of ± 30 V can be connected to pins 1 and 2 of the J6 screw terminal connector on the DT9838 module. This signal has a maximum frequency of 1 MHz and a minimum pulse width of 0.4 μ s. The threshold voltage is fixed at +2 V with 0.5 V of hysteresis.

The frequency or period of the tachometer input signal can be measured to calculate the rotation speed for high-level (± 30 V) tachometer input signals. An internal 12 MHz counter is used for the measurement, yielding a resolution of 83 ns (1/12 MHz).

The number of counts can be read between two consecutive starting edges of the tachometer input signal by including channel 4 in the analog input channel list. The starting edge is programmable (either rising or falling).

Using software commands, you can specify the following parameters for the tachometer input:

- The starting edge of the tachometer input signal to use for the measurement (rising or falling edge).
- A flag (called Stale) indicating whether or not the data is new. If the Stale flag is set as Used (the default value), the most significant bit (MSB) of the value is set to 0 to indicate new data; reading the value before the measurement is complete returns an MSB of 1. If the Stale flag is set to Not Used, the MSB is always set to 0.

When the operation is started, the internal 12 MHz counter starts incrementing when it detects the first starting edge of the tachometer input and stops incrementing when it detects the next starting edge of the tachometer input. When the measurement is complete, the counter remains idle until it is read. On the next read, either 0 or the current value of the tachometer input (from the previous measurement operation) is returned depending on the module and the tachometer settings, described above, and the next operation is started automatically.

The software automatically synchronizes the value of the tachometer input with the analog input measurements, so that all measurements are correlated in time. The tachometer input is treated like any other channel in the analog input channel list; therefore, all the triggering and conversion modes supported for analog input channels are supported for the tachometer input.

Using the count that is returned from the tachometer input, you can determine the following:

- Frequency of a signal pulse (the number of periods per second). You can calculate the frequency as follows:
 - Frequency = 12 MHz/(Number of counts – 1) where 12 MHz is the internal counter/timer clock frequency
 - For example, if the count is 21, the measured frequency is 600 kHz (12 MHz/20).
- Period of a signal pulse. You can calculate the period as follows:
 - Period = 1/Frequency
 - Period = (Number of counts – 1)/12 MHz where 12 MHz is the internal counter/timer clock frequency

Synchronizing Acquisition on Multiple Modules

DT9838 modules provide a Sync Bus (RJ45) synchronization connector that can be used to connect and synchronize multiple DT9838 modules.

Note: DT9837A, DT9837B, and/or DT9837C modules can also be connected to the DT9838 module in this configuration.

In this scheme, one module is the master and the other modules are the slave. The synchronization mode (master, slave, or none) of the RJ45 connector is specified using software.

When configured as a master, the Sync Bus connector outputs trigger and clock signals. When configured as a slave, the Sync Bus connector accepts trigger and clock signals from the master; the start trigger source is ignored in this configuration since the Sync Bus is used as the start trigger. When configured as none (the default mode), the DT9838 module uses the USB clock instead of the Sync Bus connector. The synchronization mode remains set until changed or until the application exits.

Multiple modules can be connected in one of two ways. Figure 2 shows how to connect a maximum of two DT9838 modules by daisy chaining them together through the Sync Bus connector. Figure 3 shows how to connect a maximum of four DT9838 modules by using an RJ45 distribution panel, such as the EP386, where the panel contains four RJ45 connectors that are wired in parallel.

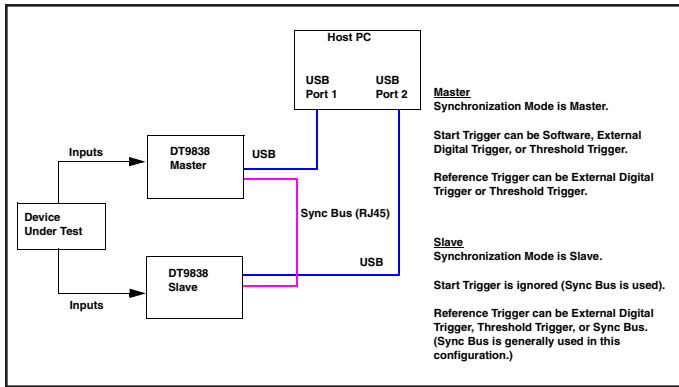

Figure 2. Synchronizing Two DT9838 Modules by Daisy Chaining the Sync Bus Connectors

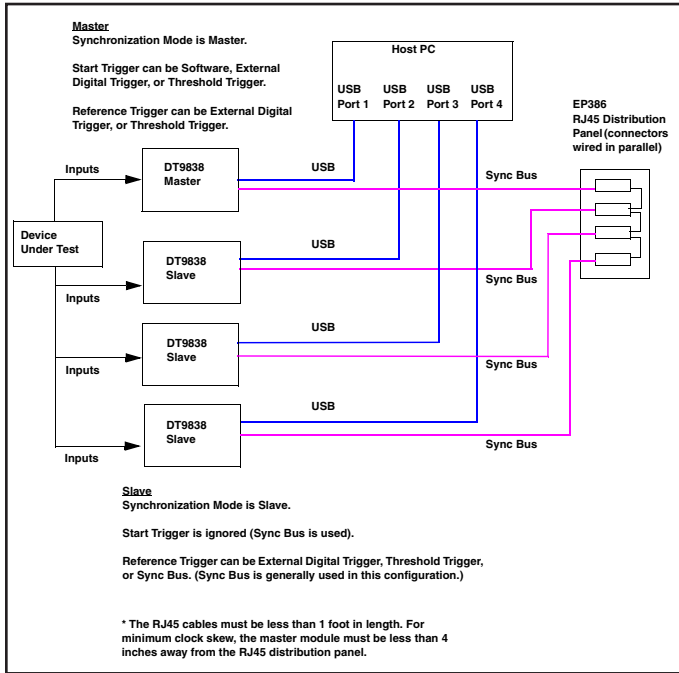

Figure 3. Synchronizing Four DT9838 Modules Using the EP386 Sync Bus Distribution Panel

When synchronizing multiple modules, start the slave modules before starting the master module. When the master module is triggered (using any of the supported trigger sources), both the master and the slave modules start acquiring data at the same time (within one A/D conversion of the clock). Note that the clock rate can be set to be the same or different on each module.

Note: It is important to start the slave modules first, followed by the master module so that the slave receives the appropriate clock and trigger signals from the master.

If the master module is started before the slaves, the slaves never start; you will see a delay of approximately 20 seconds if you try to stop or abort the analog input operation on a slave module that is waiting for a trigger.

When the master module is stopped, the slaves continue to run and return data until the analog input subsystem on the slave modules is stopped. Be sure to stop the analog input subsystems on all slave modules before disconnecting the cable from the Sync Bus connectors.

Cross-Series Compatibility Saves Programming Time, Protects Your Investment

Virtually all Data Translation data acquisition modules, including the DT9838, are compatible with the DT-Open Layers® software standard. This means any application developed with one of Data Translation's software products can be easily upgraded to a new Data Translation module with little to no reprogramming needed.

User Manual

The DT9838 module includes a user's manual that provides getting started and reference information. The manual is provided in electronic (PDF) format on the Data Acquisition Omni CD provided with the module.

Technical Support

Application engineers are available by phone and email during normal business hours to discuss your application requirements. Extensive product information, including drivers, example code, pinouts, a searchable Knowledge Base, and much more, is available 24 hours a day on our website at www.datatranslation.com.

Supported Software

The following software is available for use with the DT9838 module and is included on the Data Acquisition Omni CD:

- DT9838 Device Driver – The DT9838 Device Driver allows you to use a DT9838 module with any of the supported software packages or utilities.
- VIBpoint Framework application – This application allows you to acquire and analyze data from up to four synchronized DT9838, DT9837A, DT9837A-OEM, DT9837B, or DT9837C modules, or one DT9837 USB module. You can download a 14-day trial version of this application from the Data Translation web site (http://www.datatranslation.com/products/VIBpoint/framework_application.asp). After the trial period has elapsed, you must purchase a license to continue using this application.

Note: The VIBpoint Framework application also supports the DT8837 Series Ethernet/LXI instrument modules.

The VIBpoint Framework application lets you perform the following functions:

- Discover and select your instrument modules.
- Configure all input channel settings for the attached sensor, such as the enable state, strain measurement settings, IEPE settings, input range, tachometer edges, counter edges, and engineering units for the sensor.
- Load/save multiple hardware configurations.
- On each instrument module, acquire data from all channels supported in the input channel list.
- Log acquired data (in the time domain) to disk.
- Display acquired data during acquisition in either a digital display using the Channel Overview window or as a waveform using the Plot Area of the main window.
- Perform single-channel FFT (Fast Fourier Transforms) operations on the acquired analog input data. You can configure a number of parameters for the FFT, including the FFT size, windowing type, averaging type, integration type, and so on.
- Choose from a large number of two-channel FFT options, including: Frequency Response Functions (Inertance, Mobility, Compliance, Apparent Mass, Impedance, Dynamic Stiffness, or custom FRF) with H1, H2, or H3 estimator types, Cross-Spectrum, Power Spectral Density, Coherence, and Coherent Output Power.
- Display time domain data as it is acquired and/or after applying windowing functions.
- Display frequency domain data as Amplitude, Phase, or Nyquist.
- Configure and view statistics about the FFT data, including the frequency and value of the highest peaks.
- Open recorded data in Excel for further analysis.

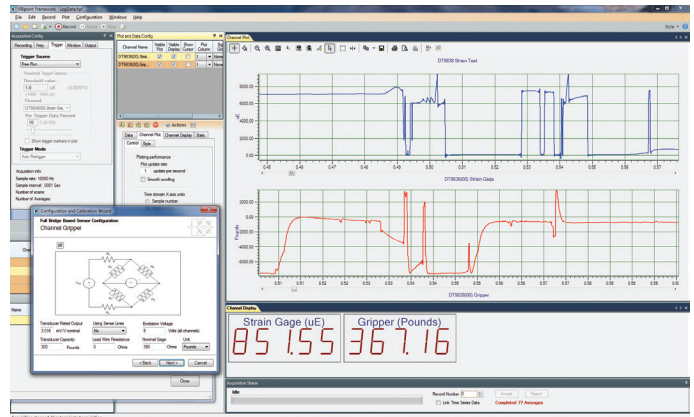

Figure 4. VIBpoint Framework application

- Customize many aspects of the acquisition, display, and recording functions to suit your needs, including the clock frequency and the trigger settings. The VIBpoint Framework application can be used in one of two modes: Acquisition mode, which allows you to acquire data, or File Reader mode, which allows you to view a previously recorded data file. Refer the documentation for the VIBpoint Framework application for detailed information about the application.

- DT-Open Layers for .NET Class Library – Use this class library if you want to use Visual C# or Visual Basic for .NET to develop your own application software for a DT9838 module using Visual Studio 2003 or Visual Studio 2005; the class library complies with the DT-Open Layers standard.
- DataAcq SDK – Use the Data Acq SDK if you want to use Visual Studio 6.0 and Microsoft C or C++ to develop your own application software for a DT9838 module using Windows XP, Windows Vista, or Windows 7; the DataAcq SDK complies with the DT-Open Layers standard.
- DAQ Adaptor for MATLAB – Data Translation's DAQ Adaptor provides an interface between the MATLAB Data Acquisition (DAQ) subsystem from The MathWorks and Data Translation's DT-Open Layers architecture.
- LV-Link – An evaluation version of LV-Link is included on the Data Acquisition OMNI CD. Use LV-Link if you want to use the LabVIEW graphical programming language to access the capabilities of the DT9838 module.

Accessories

- STP STRAIN General-Purpose Accessory – This accessory contains four general-purpose screw terminal panels. Use one screw terminal panel for each channel.
- STP STRAIN 120 Quarter-Bridge Completion Accessory – This accessory contains four screw terminal panels with a 120 Ω quarter-bridge completion resistor installed on each screw terminal panel. Use one screw terminal panel for each channel.
- STP STRAIN 350 Quarter-Bridge Completion Accessory – This accessory contains four screw terminal panels with a 350 Ω quarter-bridge completion resistor installed on each screw terminal panel. Use one screw terminal panel for each channel.
- EP398 RJ50 cables – The EP398 accessory contains four RJ50 cables that are used to connect four STP STRAIN, STP STRAIN 120, or STP STRAIN 350 screw terminal panels to the DT9838 module.
- EP394 +5V external power supply – Use this optional power supply if you want to use external +5V power to power the DT9838 module.
- EP386 panel – The EP386 panel contains four RJ45 connectors that are wired in parallel, making it useful when attaching up to four DT9838 modules together using the Sync Bus.

Ordering Information

All Data Translation hardware products are covered by a 1-year warranty. For pricing information, please visit our website or contact your local reseller.

HARDWARE

- **DT9838**
- **DT9838-OEM**

ACCESSORIES

- **EP386**
- **EP394**
- **EP398**
- **STP STRAIN**
- **STP STRAIN 120**
- **STP STRAIN 350**

SOFTWARE

The following software is available for purchase separately:

- **VIBpoint Framework**

FREE SOFTWARE

The following software is available as a free download from our website:

- **DAQ Adaptor for MATLAB**
- **LV-Link**