

PROPRIETARY AND CONFIDENTIAL

THE INFORMATION CONTAINED IN THIS DRAWING IS THE SOLE PROPERTY OF DYTRAN INSTRUMENTS INC. ANY REPRODUCTION IN PART OR AS A WHOLE WITHOUT THE WRITTEN PERMISSION OF DYTRAN INSTRUMENTS, INC. IS PROHIBITED

REVISIONS

REV.	ECN	DESCRIPTION	BY/DATE	CHK	APPR
A	5743	ADDED NOTE 1	RA, 2/04/09	fy 2-13-09	AWS 2/10/09

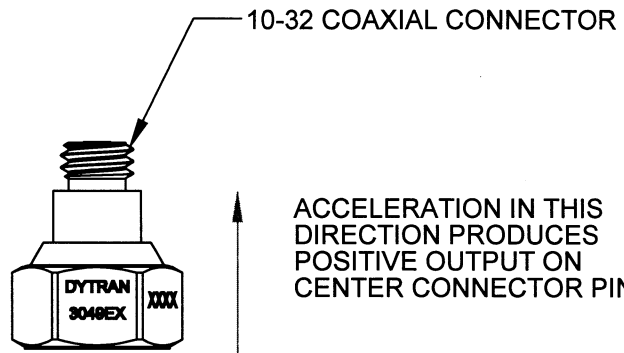
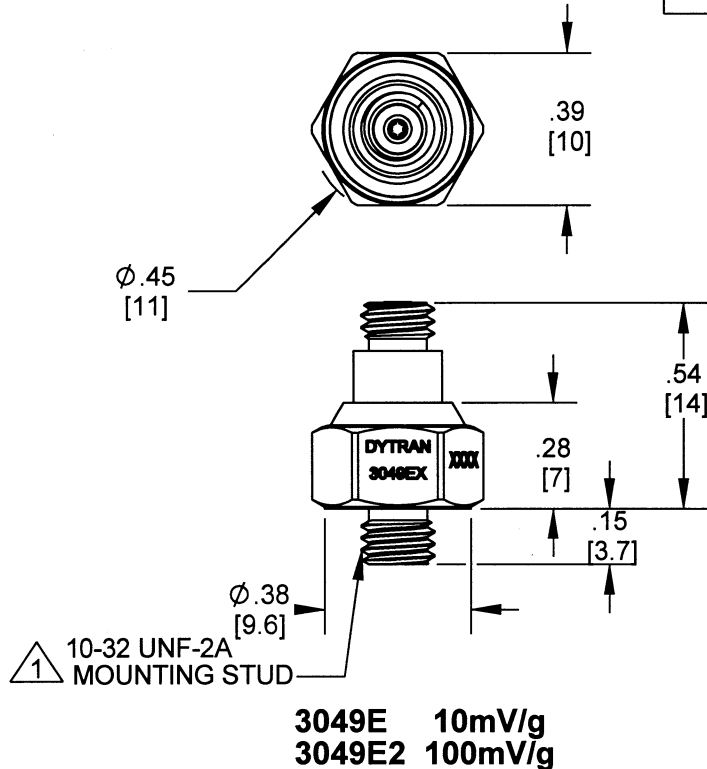

ACCELERATION IN THIS DIRECTION PRODUCES POSITIVE OUTPUT ON CENTER CONNECTOR PIN

3049E 10mV/g
3049E2 100mV/g

3049E1 10mV/g
3049E3 100mV/g

1 MOUNTING TORQUE TO: 8-10 lb-in
NOTES: UNLESS OTHERWISE SPECIFIED

MODEL	REV	ECN	DATE	SENSITIVITY	MOUNTING	WEIGHT
3049E	A	5743	2/04/09	10 mV/g	STUD	3.3 GRAMS
3049E1	A	5743	2/04/09	10 mV/g	ADHESIVE	3.1 GRAMS
3049E2	A	5743	2/04/09	100 mV/g	STUD	3.3 GRAMS
3049E3	A	5743	2/04/09	100 mV/g	ADHESIVE	3.1 GRAMS

3049E	USED ON	NEXT ASSY
APPLICATION		
THIRD ANGLE PROJECTION USA		

UNLESS OTHERWISE SPECIFIED:
INTERPRET DIM & TOL PER ASME Y14.5M - 1994.
REMOVE BURRS.
COUNTERSINK INTERNAL THDS 90° TO MAJOR DIA.
CHAM EXT THDS 45° TO MINOR DIA.
THD LENGTHS AND DEPTHS ARE FOR MIN FULL THDS.
THDS PER MIL-S-7742.
DIMENSIONS APPLY AFTER FINISHING.
ALL MACHINED SURFACES.
TOTAL RUNOUT WITHIN .005.
BREAK SHARP EDGES .005 TO .010.
MACHINED FILLET RADII .005 TO .015.
WELDING SYMBOLS PER AWS A2.4.
ABBREVIATIONS PER MIL-STD-12.

UNLESS OTHERWISE SPECIFIED:
DIMENSIONS ARE IN INCHES.
DIMENSIONS IN BRACKETS [] ARE IN MILLIMETERS
TOLERANCES ARE:
INCHES METRIC ANGLES
.XX ± .03 X ± 0.8 ± 1°
.XXX ± .010 .XX ± 0.25

MATERIAL

FINISH

DO NOT SCALE DRAWING

CONTRACT NO.

APPROVALS		DATE
ORIG	PML	12/19/05
CHK	PML	4/17/05
APP	PML	4/17/06
APP		

DYTRAN INSTRUMENTS, INC. MASTER ONLY IF IN RED
Chatsworth, CA

TITLE: **OUTLINE/INSTALLATION DRAWING, 3049E SERIES**

SIZE A	CAGE CODE 2W033	DWG. NO. 127-3049E	REV A
SCALE: 4:1	SOLIDWORKS	SHEET 1 OF 1	



SPECIFICATIONS
MODEL SERIES 3049E Series IEPE ACCELEROMETERS

SPECIFICATION					VALUE	UNITS
PHYSICAL						
WEIGHT	3049E, 3049E2				3.3	grams
	3049E1, 304E3				3.1	grams
SIZE, HEX x HEIGHT (all models)					.39 x .54	inches
MOUNTING PROVISION	3049E, 3049E2				10-32 integral stud x .15	inch
	3049E1, 3049E3				adhesive	
CONNECTOR, TOP MOUNTED					10-32	coaxial
MATERIAL, BASE, CAP & CONNECTOR					titanium alloy	
SEISMIC ELEMENT TYPE					ceramic, annular shear	
PERFORMANCE						
	3049E	3049E1	3049E2	3049E3		
SENSITIVITY, ± 5% [1]	10	10	100	100		mV/g
RANGE F.S. FOR ± 5 VOLTS OUTPUT	± 500	±500	±50	±50		g
FREQUENCY RANGE, ± 5% (all models)			1 to 10,000			Hz
RESONANT FREQUENCY, NOM. (all models)			35			kHz
EQUIVALENT ELECTRICAL NOISE	.002	.002	.001	.001		grms
BASE STRAIN SENSITIVITY	.004	.004	.004	.004		eq g/μe
LINEARITY [2] (all models)			±2			% F.S.
TRANSVERSE SENSITIVITY, MAX. (all models)			5			%
ENVIRONMENTAL						
	3049E	3049E1	3049E2	3049E3		
MAXIMUM VIBRATION	600	600	200	200		g pk
MAXIMUM SHOCK (all models)			5000			g pk
TEMPERATURE RANGE min	-60	-60	-60	-60		°F
max	250	250	212	212		°F
SEAL, HERMETIC (all models)			glass-to-metal/welded			
COEFFICIENT OF THERMAL SENSITIVITY			.06			%°F
ELECTRICAL						
SUPPLY CURRENT [3]		2 to 20				mA
COMPLIANCE VOLTAGE RANGE		+18 to +30				Volts
OUTPUT IMPEDANCE, TYP.		100				Ω
BIAS VOLTAGE.		+11 to +13				Vdc
DISCHARGE TIME CONSTANT, MIN.		0.5				Sec
OUTPUT SIGNAL POLARITY		positive				
FOR ACCELERATION TOWARD TOP						
ELECTRICAL ISOLATION, MIN		10				MΩ
CASE GROUND TO MOUNTING SURFACE						

Accessories supplied: none

[1] Measured at 100 Hz, 1 grms per ISA RP 37.2.

[2] Measured using zero-based best straight line method, % of F.S. or any lesser range.

[3] Do not apply power to this device without current limiting, 20 mA MAX. To do so will destroy the integral IC amplifier.